

Teamsonic Industrial Co., Ltd.

Specification of Plastic mylar speaker

our P/No.	P2580PE1	Size	25 x 80 mm
Test Items	Rated Requirements	Test Conditions	
1. Shape	Ellipse		
2. Type	Plastic paper speaker	Plastic frame	
3. Voice Coil Imped.	4 $\Omega \pm 15\%$	at 1.0KHz 1.0 V	
4. Resonance Freq.	400 \pm 80 Hz	without baffle (free air)	
5. Output S. P. L.	84 \pm 3 dB at 0.8, 1.0, 1.2, 1.5K Hz	1.0 W/ 0.5M distance	
6. Rated Freq. Resp.	300 - 20K Hz		
7. Distortion	Max. 10% at 1.0KHz 0.5 W		
8. Rated Input Power	3.0 W	input 3.46 V	
9. Max. Input Power	4.5 W		
10. Net Weight	17 g		
11. Baffle Opening	22.2 x 51.5 mm		

Unit: mm

2. Drawing:

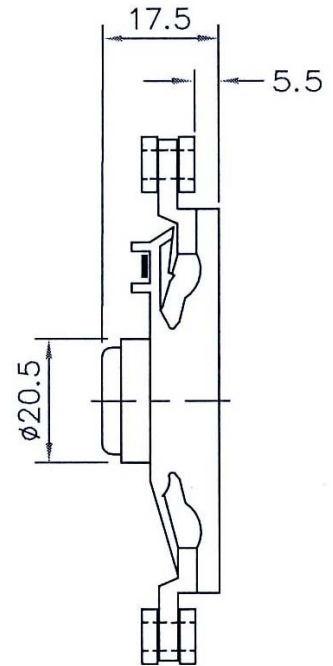
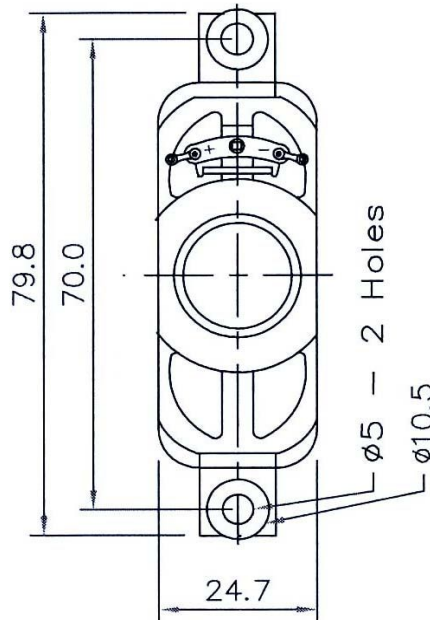

ESC End

D A S Frequency Response

26.06.11214:49

Distance Loudsp.- Mic.: 20.0 cm, dB SPL standardised to 1 meter

File: NoName

